

Reach-All, LLC

4788 1st Ave N

Duluth, MN 55803

Ph: 941-256-4165

www.reachallplatforms.com

tim@reachallplatforms.com

CraneMate Phase Lifter

**The Universal Pin-On Crane Jib
Boom Phase Lifter and Platform
with a
Self-Contained Power Unit**

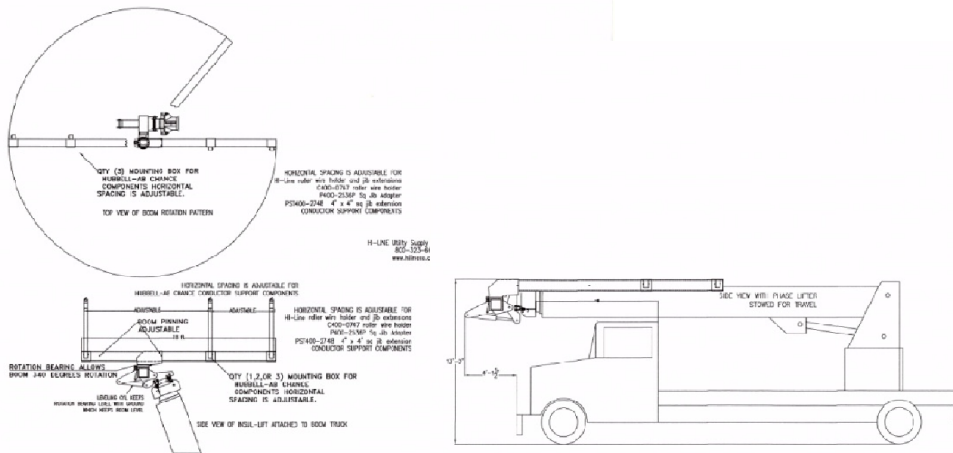

The ***CraneMate Phase Lifter Jib Boom*** pins to your crane's existing swing jib sheave head. The attachment design can transform many existing cranes (equipped with boom function radio remotes) into highly specialized insulated aerial lift bucket trucks. Excellent for delicate transmission line work; fiberglass basket optional.

The attachment Phase Lifter jib boom has both 90° hydraulic articulation with auto leveling of jib boom and 350 degrees of jib boom hydraulic rotation. The self-contained 12-volt hydraulic power package includes an integral radio remote proportional control package to control both jib boom and basket features.

Crane Requirements:

- Crane design must be approved for platform attachment
- Crane should have a swing jib sheave head design with 4 pin points
- A valid load capacity and work range chart for specific model of crane must be provided
- Work range and platform capacity are dependent on crane capacity
- One of several requirements to achieve compliance with ANSI 92.2 includes radio remote boom controls at platform

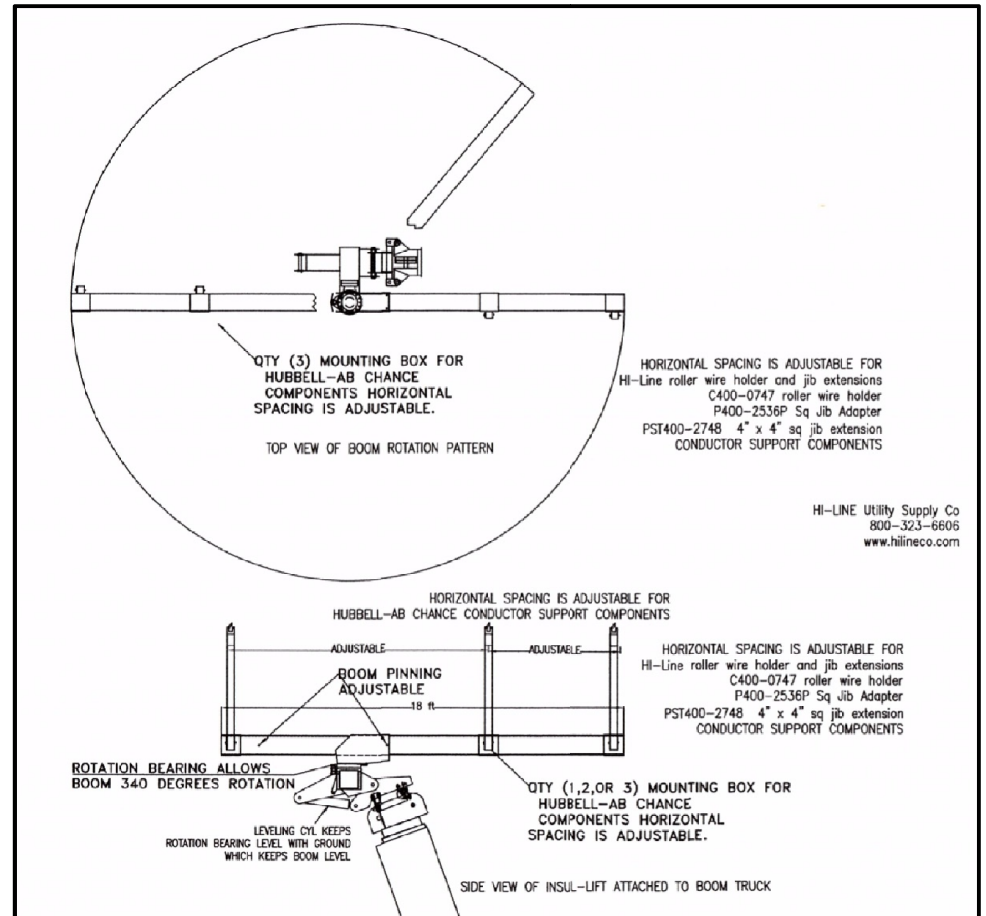
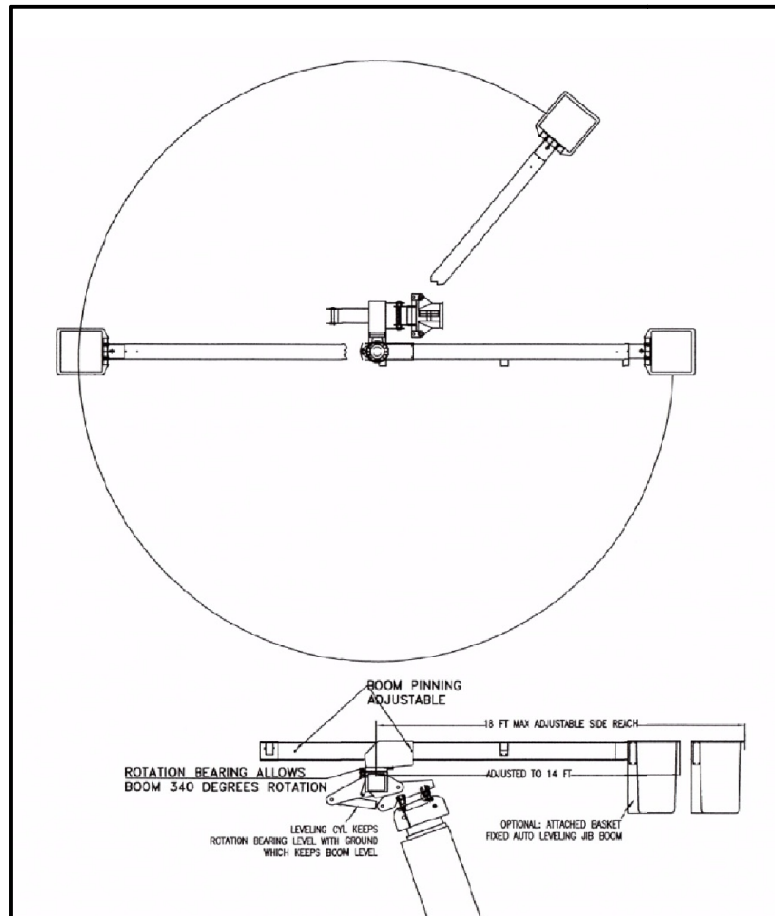
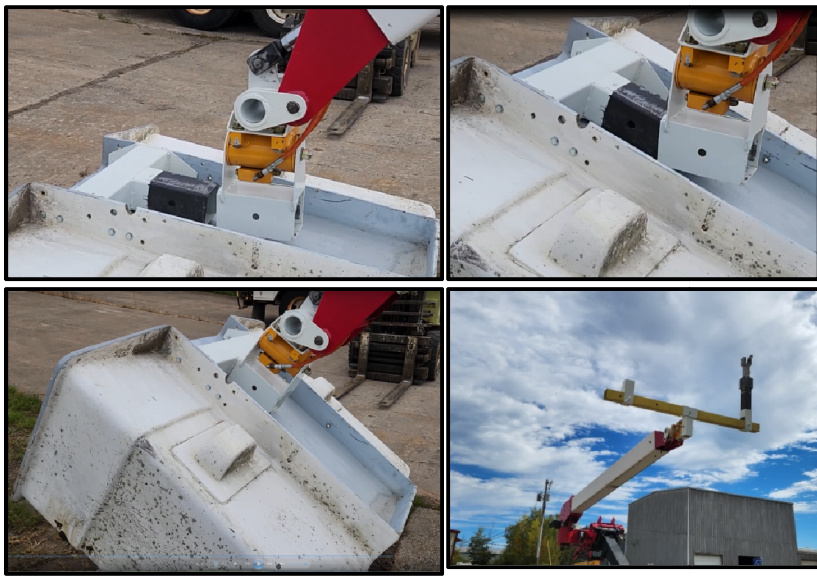

Reach-All's CraneMate Phase Lifter Jib Boom

Reach-All's *CraneMate Phase Lifter* is a self-contained jib boom that connects quickly to the head of a crane's swing jib with just 4 universal pins. It comes complete with a battery-powered onboard hydraulic system and all platform controls.

Features include an electronic leveling sensor and radio remote controls for leveling override and proportional platform rotation control and a foot-actuated auto leveling enable control switch.

Configurations: Single, double or up to three variable positioned vertical fiberglass wire lifters.

Jib Boom Lengths: 16'

Optional Basket: 180° hydraulic rotation and hydraulic auto leveling of two man fiberglass basket dimension:

48"L x 24"W x 42"D Capacity: 600 lb.

Main Phase Lifter jib boom has 350° hydraulic rotation and 90° vertical hydraulic articulation with auto and manual leveling controls.

Storage Fixture with stirrups for fork lift.

Stows to crane's boom for road travel and instant action on the jobsite!

Quickly transforms a crane into a one-of-a-kind state-of-the-art aerial bucket truck.

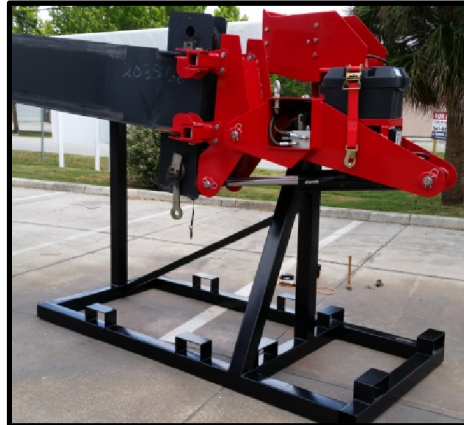

CraneMate Jib Boom

*Expand Your Reach
With Reach-All*

Option:

- After market conversion kit to meet ANSI 92.2 certification of crane to eliminate need for test weights when also equipped with platform controls

For more info or videos view website www.reachallplatforms.com